

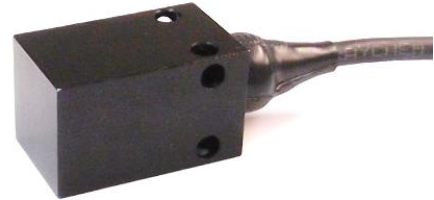

Sense
Measure
Control

Model KAH Hub Accelerometer

- **Miniature Size**
- **DC response**
- **1 Axis**
- **Ranges $\pm 2g$ to $\pm 200g$**
- **Rugged Construction**



The KAH Series of miniature accelerometers offer a compact yet robust solution for the motor sports industry.

Measurements of true vehicle dynamics are possible with the ability to measure static (dc) and dynamic accelerations.

Applications include: Hub acceleration, suspension test, aero performance, body vibration.

KA Sensors Ltd have over 15 years of experience with transducer applications in motor sport, we are therefore able to fully understand the complex requirements of racing and are available to assist with any application

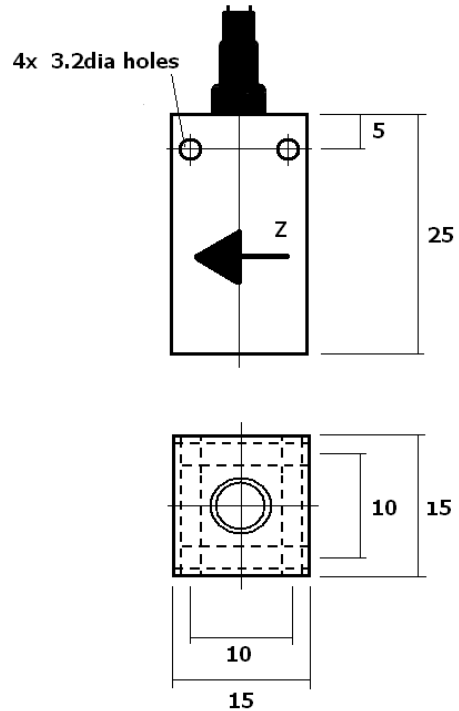

Overrange	4,000g
Linearity	$\pm 0.3\%$
Cross axis sens	$\pm 2\%$ FS ($\pm 5\%</math> for >20g)$
Resonant freq	5kHz
Operating temp	-55 to +125°C
Storage temp	-55 to +150°C
Compensated temp	-20 to +70°C
Temp effect on zero	$\pm 0.03\%$ FS/°C
Temp effect on sens	$\pm 0.02\%$ of reading/°C
Construction	Anodised aluminium
Cable	1 metre cable
Environmental	IP65
Weight	<math>< 20</math>grammes without cable

Model	Range ($\pm g$)	Supply (V)	Offset (V) ($\pm 1\%$)	Sensitivity (V) ($\pm 1\%$)	Bandwidth (Hz) max ($\pm 10\%$)	Noise (mg/ \sqrt{Hz})
KAH-2g-s	2	s = 5 (5V)	2.5	± 2.0	Hz=1500	0.3
KAH-5g-s	5				Hz=1500	0.25
KAH-10g-s	10				Hz=1500	0.32
KAH-20g-s	20	s = 12 (8-16V)	2.5	± 2.0	Hz=400	3
KAH-50g-s	50				Hz=400	3
KAH-100g-s	100				Hz=400	10
KAH-200g-s	200				Hz=400	15

KAH.1211

KA Sensors Ltd – The Old Malthouse – Springfield Road – Grantham – NG31 7BG – UK
 Tel: +44 (0)1476 568057 Fax: +44 (0)1476 561495
 Email: sales@kasensors.co.uk Web: www.kasensors.co.uk