

KA Sensors Ltd

Sensing - Measurement - Control Solutions for Motor Sports

- **Miniature size**
- **1 or 2 Axes**
- **Ranges from $\pm 2g$ to $\pm 200g$**
- **Customised bandwidth**
- **Low cost**
- **Rugged construction**

The KAA Series of miniature accelerometers offer a compact yet robust solution for the motor sports industry.

Measurements of true vehicle dynamics are possible with the ability to measure static (dc) and dynamic accelerations.

Applications include track mapping, cornering, braking, suspension test, aero performance, lean angle.

KA Sensors Ltd have over 15 years of experience with transducer applications in motor sport, we are therefore able to fully understand the complex requirements of racing and are available to assist with any application.

Overrange: 4,000g
Linearity: $< \pm 0.3\%$ FS
Cross axis sens: $< \pm 2\%$ FS ($\pm 5\%$ for $> 20g$)
Resonant freq: 5kHz

Operating temp: -55 to +125°C
Storage temp: -55 to +150°C
Compensated temp: -20 to +70°C
Temp effect on zero: $< \pm 0.03\%$ FS/°C
Temp effect on sens: $< \pm 0.02\%$ of reading/°C
Construction: Anodised aluminium
Cable: 1 metre cable
Environmental: IP65
Weight: < 30 grammes without cable

KAA Series High Level Output Accelerometer

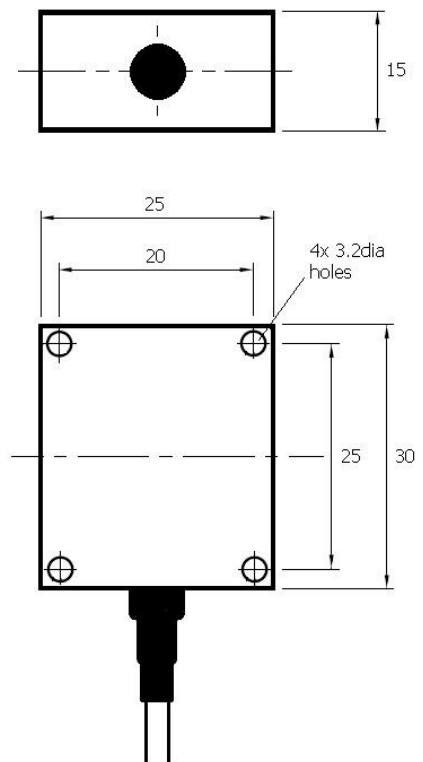
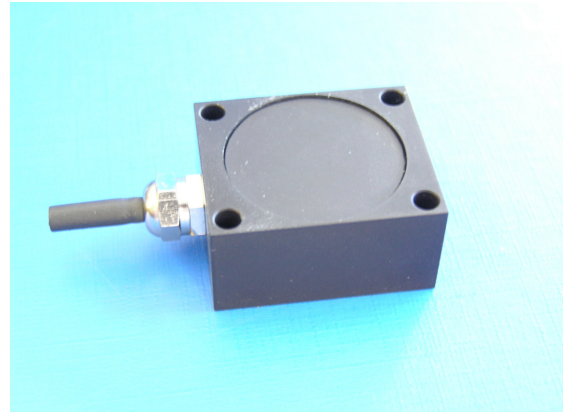

Model	Range ($\pm g$)	Supply (V)	Offset (V) ($\pm 1\%$)	Sensitivity (V) ($\pm 1\%$)	Bandwidth (Hz) max ($\pm 10\%$)	Noise (mg/ \sqrt{Hz})
KAA-2g-s-hz	2	s = 5 (5V)	2.5	± 2.0	Hz=1500	0.3
KAA-5g-s-hz	5				Hz=1500	0.25
KAA-10g-s-hz	10				Hz=1500	0.32
KAA-20g-s-hz	20				Hz=400	3
KAA-50g-s-hz	50	s = 12 (8-16V)			Hz=400	3
KAA-100g-s-hz	100				Hz=400	10
KAA-200g-s-hz	200				Hz=400	15