

KA Sensors Ltd

Sensing - Measurement - Control Solutions for Motor Sports

- **Direct replacement for OE sensor**
- **Rugged construction**
- **Resistant to standard Motorsport fluids**
- **Low cost**

The KA-HDFV crank sensor is a direct replacement for the Cosworth OE crank sensor as fitted to the DF Series of engines and its derivatives.

KA Sensors Ltd have over 15 years of experience with transducer applications in motor sport, we are therefore able to fully understand the complex requirements of racing and are available to assist with any application.

Supply:	6 - 16V
Current:	6mA max
Operating temp:	-40 to +110°C
Construction:	Aluminium case, Epoxy sensing face
Cable:	1.5m Raychem screened + DR25 over sleeve

KA-HDFV Hall Effect Crank Sensor (Cosworth DFV Engine)

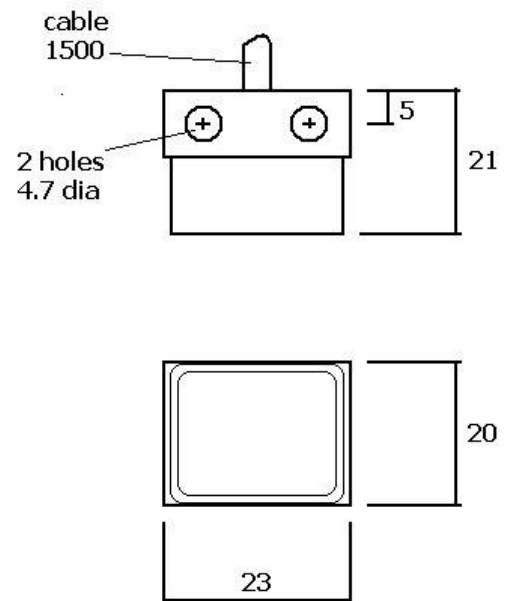

E & OE 12/06