

DMP 334

Industrial Pressure Transmitter

- ▶ thinfilm sensor
- ▶ extremely robust and long term stable
- ▶ accuracy:
0.175% / 0.125% FSO BFSL (0.35% /
0.25% FSO IEC 60770)
- ▶ nominal pressure ranges
from 0 ... 600 bar
up to 0 ... 2200 bar

The DMP 334 pressure transmitter is specially designed for use in hydraulic equipment under severe operation conditions.

Basic element of the DMP 334 is a thinfilm sensor which is welded onto a pressure port. This way - together with the solid construction - a pressure transmitter has been created that fulfills perfectly the requirements of machine and equipment manufacturers for sure operation and high reliability.

These features of the DMP 334, combined with excellent measuring parameters and good offset stability, offer the user an easy-to-use, reliable and rugged pressure transmitter.

The DMP 334 is available with all pressure ports commonly used in very high pressure systems. In addition, the customer can choose between different electrical connections.

Use for hydraulic systems in:

- ▶ hydraulic presses
- ▶ injection moulding machines
- ▶ handling equipment and mobile hydraulics
- ▶ elevated platforms
- ▶ test stands

- ▶ small thermal effect
- ▶ excellent linearity
- ▶ good long term stability
- ▶ option Ex: II 1 G EEx ia IIC T4
(only for 4 ... 20 mA / 2-wire)
(TÜV 03 ATEX 2006 X)
- ▶ option: field housing
- ▶ customer specific versions:
 - variety of electrical and mechanical connections
 - other versions on request

Characteristics



DMP 334

Industrial Pressure Transmitter

Pressure - Temperature - Level - Flow - Analytical - Control - Indication - Logging

Input pressure range						
Nominal pressure gauge [bar]		600	1000	1600	2000	2200
Permissible overpressure [bar]		800	1400	2200	2800	2800

Output signal / Supply			
Standard	2-wire:	4 ... 20 mA / $V_S = 12 \dots 36 \text{ V}_{DC}$	Ex-protection: $V_S = 14 \dots 28 \text{ V}_{DC}$
Optional	3-wire:	0 ... 20 mA / $V_S = 14 \dots 36 \text{ V}_{DC}$	
		0 ... 10 V / $V_S = 14 \dots 36 \text{ V}_{DC}$	

Performance			
Accuracy ¹	standard:	$\leq \pm 0.35 \%$ FSO	(BFSL: $\leq \pm 0.175 \%$ FSO)
	option (on request):	$\leq \pm 0.25 \%$ FSO	(BFSL: $\leq \pm 0.125 \%$ FSO)
Permissible load	current 2-wire:	$R_{max} = [(V_S - V_{Smin}) / 0.02] \Omega$	
	current 3-wire:	$R_{max} = 500 \Omega$	
	voltage 3-wire:	$R_{min} = 10 \text{ k}\Omega$	
Long term stability	$\leq \pm 0.2 \%$ FSO / year		
Influence effects	supply:	0.05% FSO / 10 V	
	load:	0.05% FSO / $\text{k}\Omega$	

Thermal effects	
Thermal error for offset and span in compensated range	$\leq \pm 0.25 \%$ FSO / 10 K -20 ... 85 °C

Electrical protection	
Short-circuit protection	permanent
Reverse polarity protection	no damage, but also no function
Electromagnetic compatibility	emission and immunity according to EN 61326
Option Ex-protection DX13-DMP 334	II 1 G EEx ia IIC T4 (only with 4 ... 20 mA / 2-wire) safety technical maximum values: $V_i = 28 \text{ V}$, $I_i = 93 \text{ mA}$, $P_i = 660 \text{ mW}$

Mechanical stability	
Vibration	10 g RMS (20 ... 2000 Hz)
Shock	100 g / 11 ms

Permissible temperatures	
Medium	-40 ... 140 °C
Electronics / environment	-25 ... 85 °C
Storage	-40 ... 125 °C

¹ accuracy according to IEC 60770 – limit point adjustment (non-linearity, hysteresis, repeatability)

Pressure - Temperature - Level - Flow - Analytical - Control - Indication - Logging

Mechanical connection

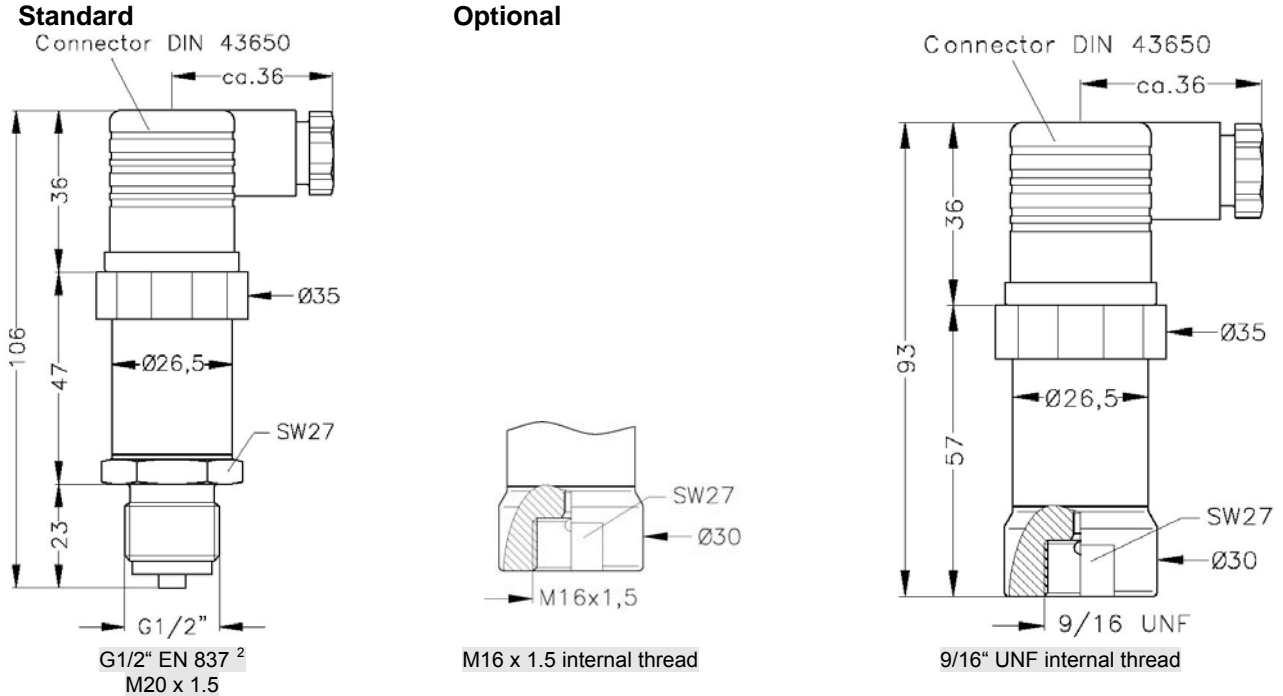

⇒ Ex-protection: total length increases by 17 mm!

Electrical connection

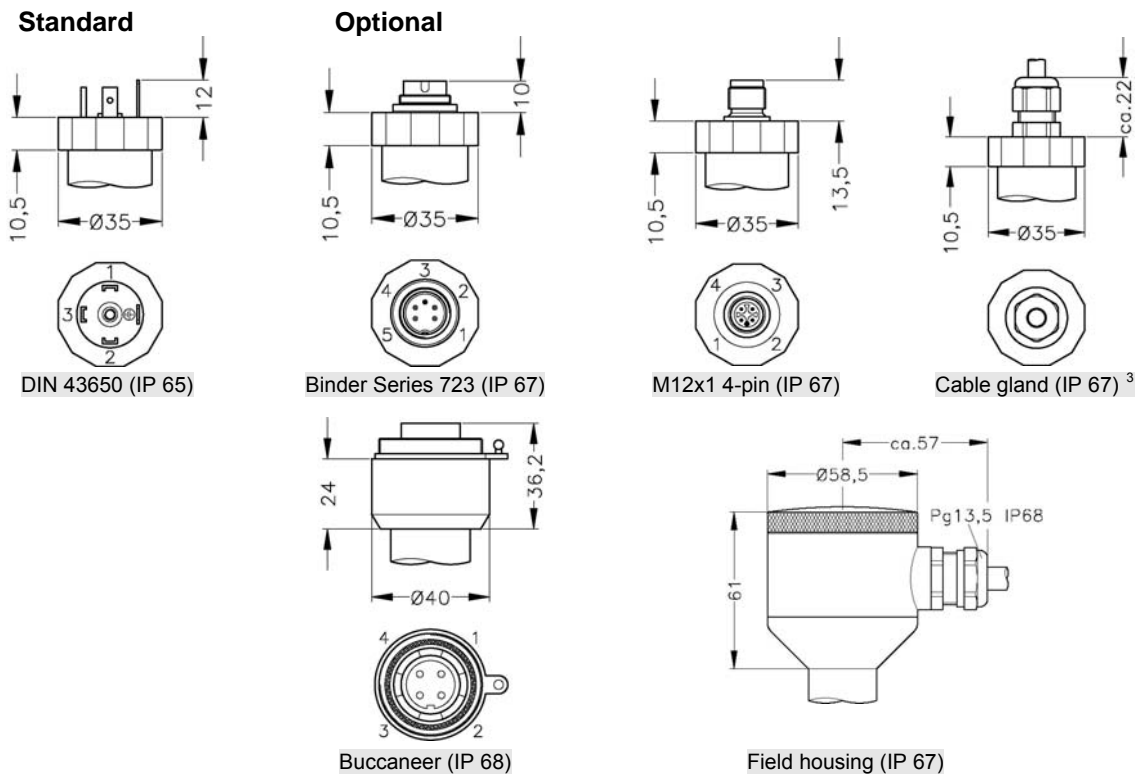

² According to EN 837, the pressure port and the complement, at pressure value over 1000 bar must be preferably made of stainless steel with a tensile strength of $R_p > 260 \text{ N/mm}^2$ in accordance with DIN 17440. The maximum allowed pressure is 1600 bar!

³ different cable types and lengths available, standard: 2 m PVC cable

Visit the website: www.impress-sensors.co.uk

Pressure - Temperature - Level - Flow - Analytical - Control - Indication - Logging

Materials	
Pressure port	stainless steel 1.4542 (17-4PH)
Housing	stainless steel 1.4301 (304) / field housing: 1.4305 (303), cable gland: brass, nickel plated
Seals (media wetted)	none (welded version)
Diaphragm	stainless steel 1.4542 (17-4PH)
Media wetted parts	pressure port, diaphragm

Miscellaneous	
Current consumption	signal output current: max. 25 mA signal output voltage: max. 7 mA
Weight	approx. 200 g
Installation position	any

Pin configuration		DIN 43650	Binder 723 (5-pin)	M12x1 (4-pin)	Buccaneer (4-pin)	cable colours (DIN 47100)
2-wire-system	Supply +	1	3	1	1	white
	Supply -	2	4	2	2	brown
	Ground	ground pin	5	4	4	yellow / black
3-wire-system	Supply +	1	3	1	1	white
	Supply -	2	4	2	2	brown
	Signal +	3	1	3	3	green
	Ground	ground pin	5	4	4	yellow / black

Wiring diagrams

2-wire-system (current)

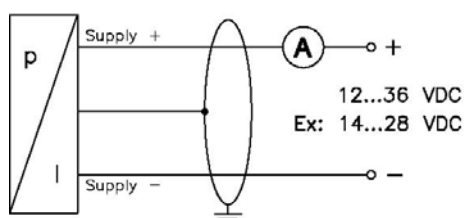

3-wire-system (current)

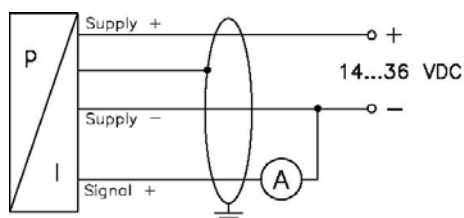

3-wire-system (voltage)

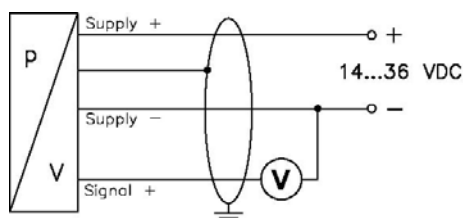

This data sheet contains product specification; properties are not guaranteed. Subject to change without notices.

Visit the website: www.impress-sensors.co.uk